

1. Product Introduction

AH423 is a unipolar Hall switch chip with high voltage resistance and high sensitivity, which is designed by bipolar semiconductor technology. The chip is composed of voltage stabilizing unit, Hall voltage generator, differential amplifier circuit, temperature compensation circuit and Open collector output circuit. Working mode: input Magnetic flux density and output digital voltage signal. Provide TO92S inline packaging, SMT SOT23-3L packaging, and all packaging meets RoHS standards.



2. Function

- Micro structure
- Open collector output
- ESD: $\pm 4\text{kV}$
- High sensitivity: 120/80Gs (typical value)
- Wide voltage range: 3.5V~40V
- Operating temperature range: $-40^{\circ}\text{C}\sim 125^{\circ}\text{C}$

3. Application

- Brushless motor commutation
- Flow sensor
- Position sensor
- Speed sensor
- Distance sensor

4. Product packaging

Part No.	Packages	Temperature range	Packing
AH423UA	TO92S	$-40^{\circ}\text{C}\sim 125^{\circ}\text{C}$	1000/bag
AH423SU	SOT23-3L	$-40^{\circ}\text{C}\sim 125^{\circ}\text{C}$	3000/ reel

Contents

1. Product Introduction	1
2. Function	1
3. Application.....	1
4. Product packaging.....	1
5. Functional Block Diagram.....	3
6. Pin information	3
7. Magnetolectric conversion characteristics	3
8. Limit parameter.....	4
9. Electromagnetic characteristics	4
10. Temperature Performance	5
11. Application Circuit.....	5
12. Package Material Information.....	6
13. Historic version.....	8
14. Notes	8

AH423

High voltage resistance and high sensitivity unipolar Hall chip



5. Functional Block Diagram

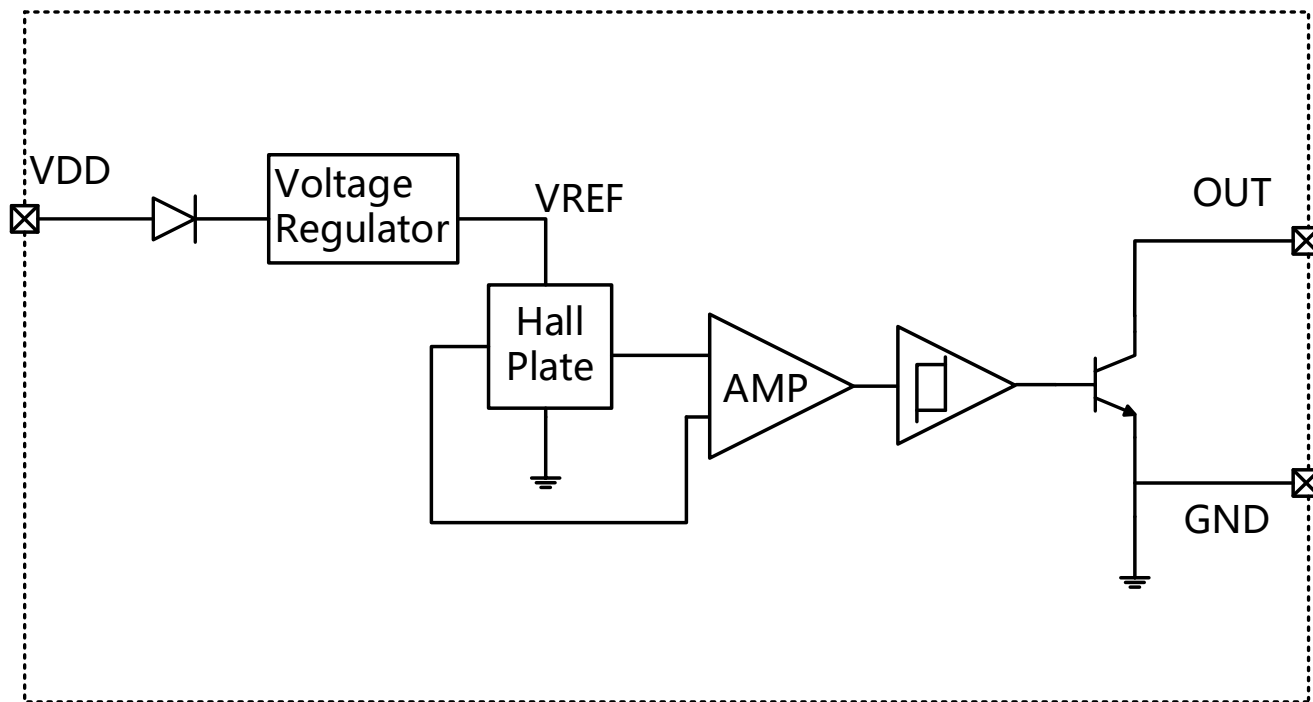

6. Pin information

No.	Name	Functions
1	V _{CC}	Power supply
2	GND	Ground
3	V _{OUT}	Output

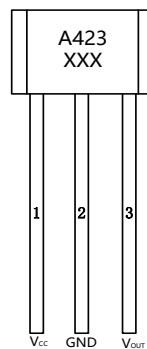

TO92S

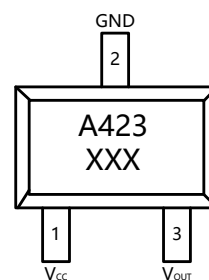

SOT23-3L

7. Magnetoelectric conversion characteristics

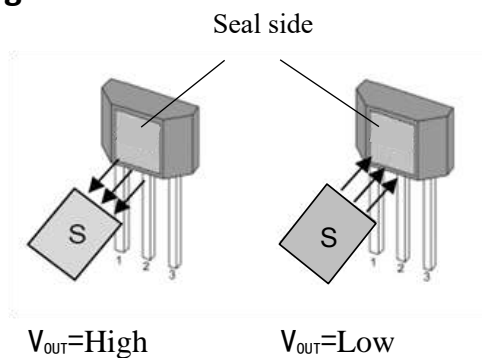

V_{OUT}=High

V_{OUT}=Low

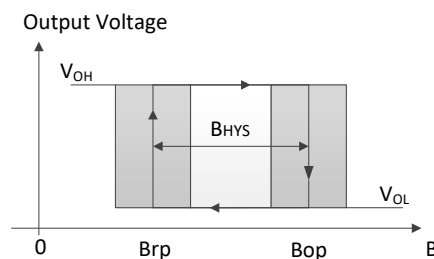

TO92S output status

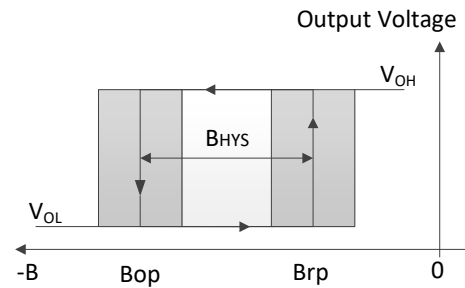
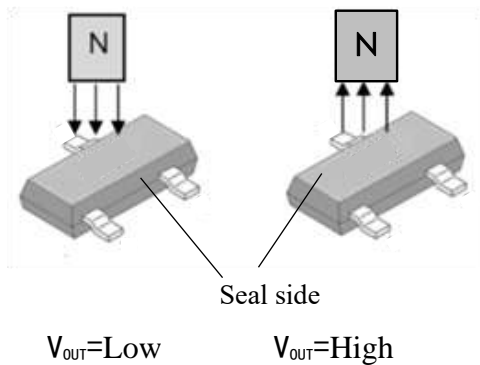

SOT23-3L output status

8. Limit parameter

Parameters	Symbols	Min	Max	Units
Power supply voltage	V_{CC}	-0.3	60	V
Output voltage	V_{OUT}	-0.5	60	V
Output current	I_{OUT}	0	40	mA
Operating temperature	T_J	-40	125	°C
storage temperature	T_{STG}	-50	165	°C

The absolute maximum rating is the limit value that a chip can withstand, and exceeding this value may cause permanent damage to the chip.

9. Electromagnetic characteristics

Parameters	Symbols	Test conditions	Min	Typ	Max	Units
Electrical performance						
Power supply voltage	V_{CC}		3.5		40	V
Power supply current	I_{CC}	$V_{CC}=5V$		6	9	mA
Output leakage current	I_{le}				10	uA
Output voltage	V_{SAT}	$I_{OUT}=20mA$, on-state			0.4	V
Output current	I_{OUT}				30	mA
Output Rise Time	T_R	$C_L=20pF$			1.0	us
Output Fall Time	T_F	$C_L=20pF$			1.5	us
Magnetic performance						

operating point	Bop	$C_L=20\text{pF}$	70	120	170	Gs
release point	Brp		30	80	130	Gs
return difference	B_{HYS}			40		Gs

10. Temperature Performance

$V_{CC}=5\text{V}$, operating current of the chip varies with temperature performance.

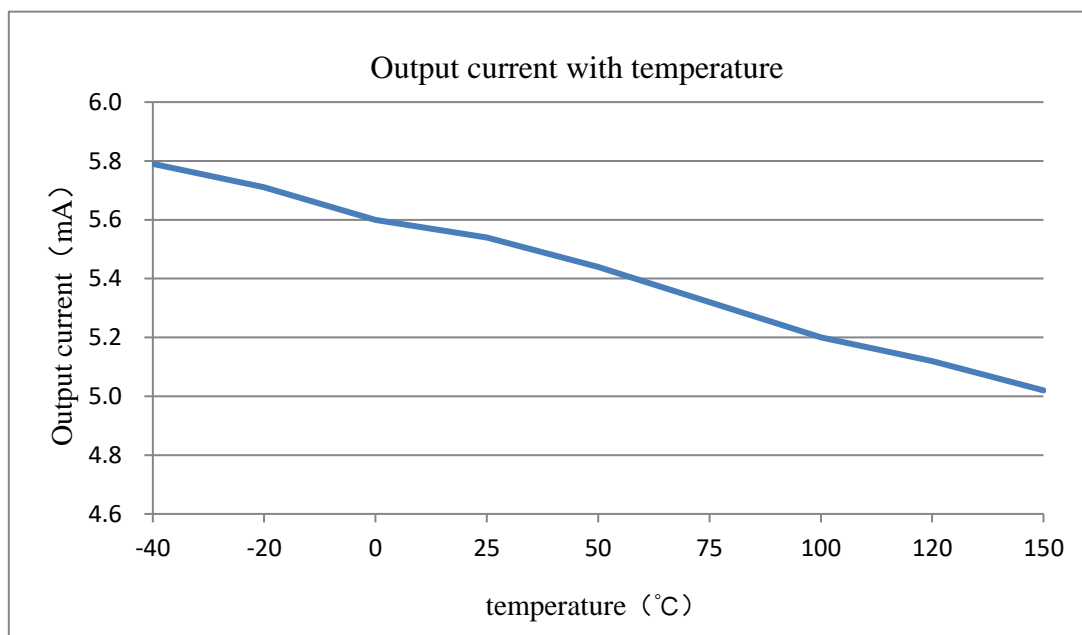

11. Application Circuit

The typical application circuit is shown in the following figure: Application circuit 1, where $R_L=4.7\text{k}\Omega$, which can be applied to most circuits. Application circuit 2, where $R_V=100\Omega$, $C_P=4.7\text{nF}$, $R_L=4.7\text{k}\Omega$, $C_L=1\text{nF}$, is suitable for circuits with interference or radiation interference on power supply lines. It is recommended to connect the resistor R_V and two capacitors C_P and C_L in series in the circuit, and place the resistor and capacitor components as close to the chip as possible.

AH423

High voltage resistance and high sensitivity unipolar Hall chip

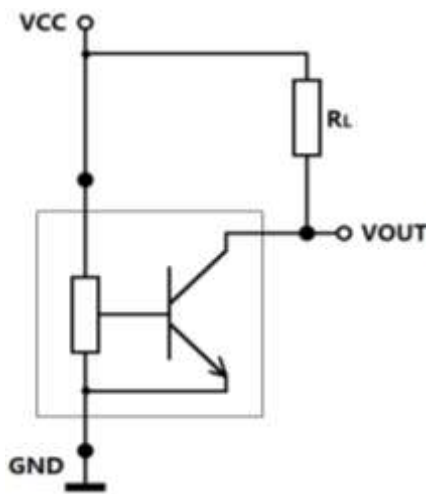

Typical Application Circuit 1

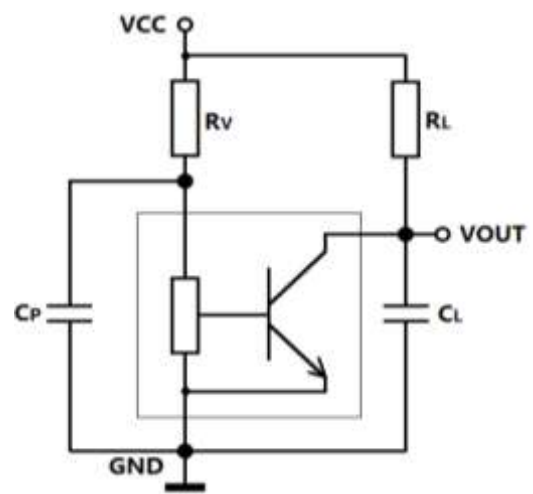

Typical Application Circuit 2

12.Package Material Information

TO92S Package Size

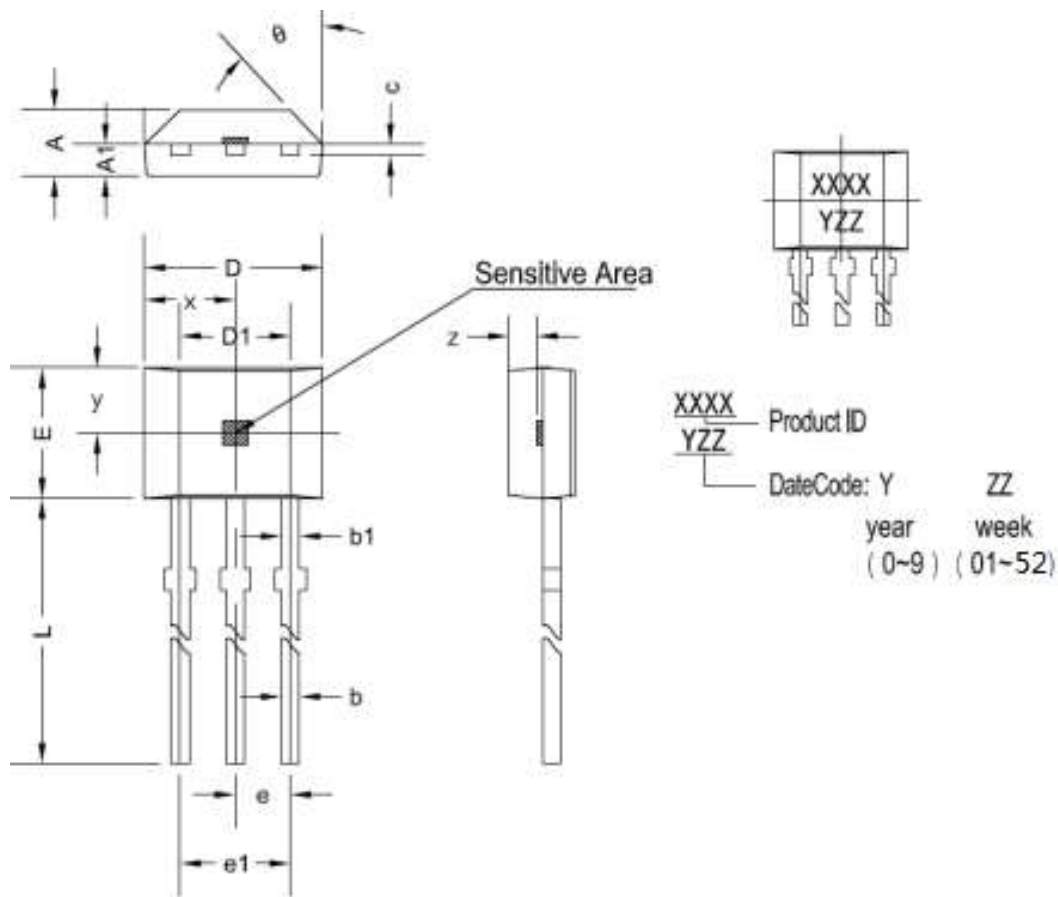

AH423

High voltage resistance and high sensitivity unipolar Hall chip



Symbol	Dimensions in Millimeters		Dimensions in Inches	
	Min	Max	Min	Max
A	1.420	1.670	0.056	0.066
A1	0.660	0.860	0.026	0.034
b	0.350	0.560	0.014	0.022
b1	0.400	0.550	0.016	0.022
C	0.360	0.510	0.014	0.020
D	3.900	4.200	0.154	0.165
D1	2.970	3.270	0.117	0.129
E	2.900	3.280	0.114	0.129
e	1.270TYP		0.050TYP	
e1	2.440	2.640	0.096	0.104
L	13.500	15.500	0.531	0.610
x	2.025TYP		0.080TYP	
y	1.545TYP		0.061TYP	
z	0.500TYP		0.020TYP	
θ	45°TYP		45°TYP	

SOT23-3L Package Size

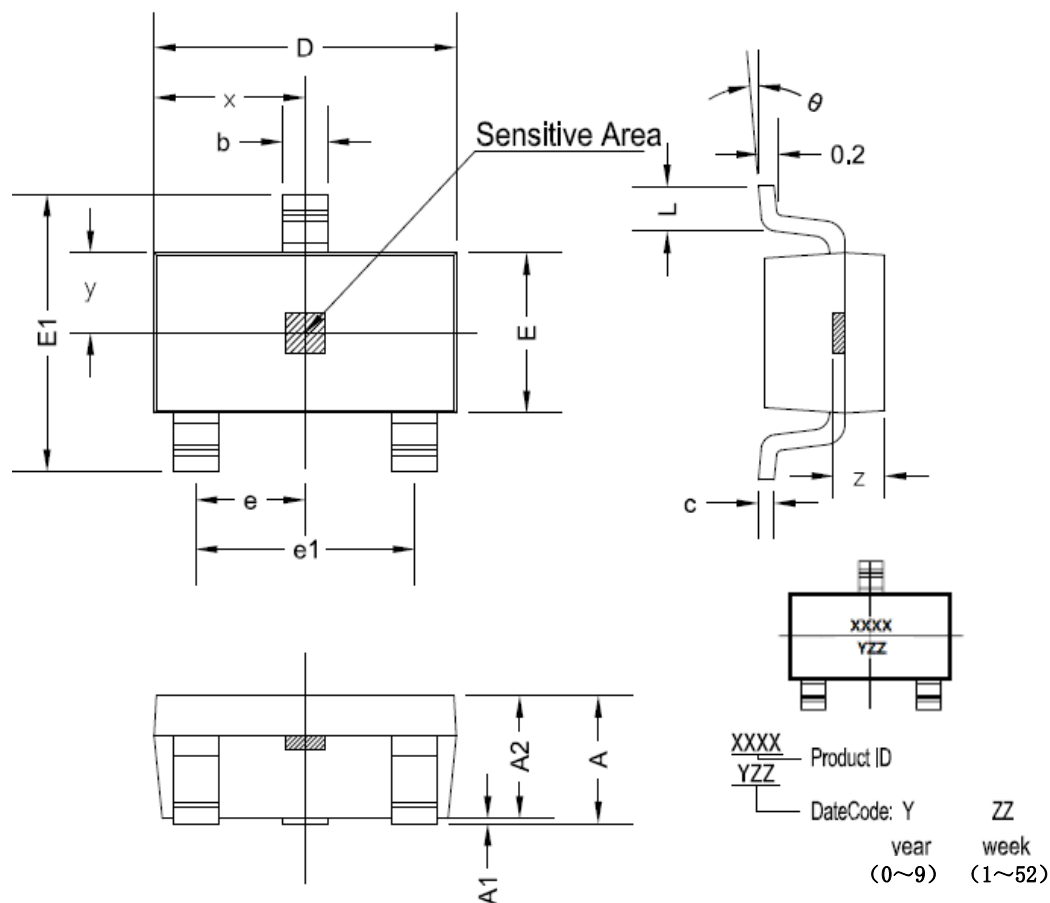

Symbol	Dimensions in Millimeters		Dimensions in Inches	
	Min	Max	Min	Max
A	1.050	1.250	0.041	0.049
A1	0.000	0.100	0.000	0.004
A2	1.050	1.150	0.041	0.045
b	0.300	0.500	0.012	0.020
c	0.100	0.200	0.004	0.008
D	2.820	3.020	0.111	0.119
E	1.500	1.700	0.059	0.067
E1	2.650	2.950	0.104	0.116
e	0.950TYP		0.037TYP	
e1	1.800	2.000	0.071	0.079
L	0.300	0.600	0.012	0.024
x	1.460TYP		0.057TYP	
y	0.800TYP		0.032TYP	
z	0.600TYP		0.024TYP	
θ	0°	8°	0°	8°

13.Historic version

Versions	Update date	modify
REV1.0	2020.07	
REV1.1	2022.07	Optimize the minimum working voltage to 3.0V and increase the temperature characteristic curve
REV1.2	2023.04	Layout and formatting

14.Notes

- Hall chips are sensitive devices, and electrostatic protection measures should be taken during use, installation, and storage.
- During installation and use, mechanical stress applied to the device casing and leads should be minimized as much as possible.
- It is recommended that the welding temperature should not exceed 350 °C and the duration should not exceed 5 seconds.
- To ensure the safety and stability of Hall chips, it is not recommended to use them beyond the parameter range for a long time.

AH423

High voltage resistance and high sensitivity unipolar Hall chip



Copyright ©2018, Alfa Electronics Co., Ltd

Alfa Electronics Co., Ltd reserves the right to make, from time to time, such departures from the detail specifications as may be required to permit improvements in the performance, reliability, or manufacturability of its products. Before placing an order, the user is cautioned to verify that the information being relied upon is current.

Alfa's products are not to be used in any devices or systems, including but not limited to life support devices or systems, in which a failure of Alfa's product can reasonably be expected to cause bodily harm.

The information included herein is believed to be accurate and reliable. However, Alfa Electronics Co., Ltd assumes no responsibility for its use; nor for any infringement of patents or other rights of third parties which may result from its use.